

The "South China Sea" may evoke associations of pirates, sharks, and dynamite fishing to quite a few, but for many more actually living in Southeast Asia, it means food and income. Much goes on, indeed, in the South China Sea area, and it still contains blank spots and dangerous reef areas on the nautical maps. Yet but most important now is how continuing deforestation and overpopulation drive more and more people towards the edge of the sea. Once there, most have no choice but to settle as small-scale fishers, and to exploit one of the few remaining open access resources: fish. Meanwhile numerous fisheries development projects

In the north, it is separated from the East China Sea by the shallow Formosa Strait while a series of even shallower sills along the Philippine coast separate the SCS from the open Pacific. Other shallow sills isolate the SCS in the south and the west. Thus, it is very likely that the SCS, which covers approximately 3.5 million km², has only minor biotic exchanges with adjacent large marine ecosystems (LMEs) and hence that it may be treated as a largely closed ecosystem.

While building the model of the SCS we encountered two general problems: i) although an almost closed

- by a variety of fixed artisanal gears.
- B. Reef flat/seagrass beds (depth: 0-10 m), especially abundant along the Philippine coast, and along with subsystem A often gleaned at low tide by women and children.
- C. Gulf of Thailand (depth: 10-50 m), exploited for pelagic fish, and by a well-documented bottom trawl fishery
- D. Coast of Vietnam/southern China (depth: 10-50 m), exploited mainly by Hongkong and Taiwan-based trawlers.
- E. Northwestern Philippines (depth: 10-

The South China Sea: Analyzing Fisheries Catch Data in an Ecosystem Context

VILLY CHRISTENSEN
DANIEL PAULY
ICLARM

have succeeded at introducing industrialized fishing in the region; this has led to depleted stocks and increasing conflicts between small-scale and large-scale fisheries.

The South China Sea is an important fishing area with an annual harvest of some 5 million tonnes on an annual basis, or some 10% of the catches jointly taken by the developing countries of the world. As a step towards increasing our understanding of the South China Sea area, we found it useful to construct a model of the area describing fisheries catches and biological interactions. To achieve this, we have collected and summarized the available biological data from the South China Sea on a resource system basis, for the period from the late 1970s to the mid-1980s.

We view the South China Sea (SCS) as a large marine ecosystem (Fig. 1).

Fig. 1. The South China Sea as defined in this contribution covers 3.5 million km² of mainly shallow waters (< 200 m).

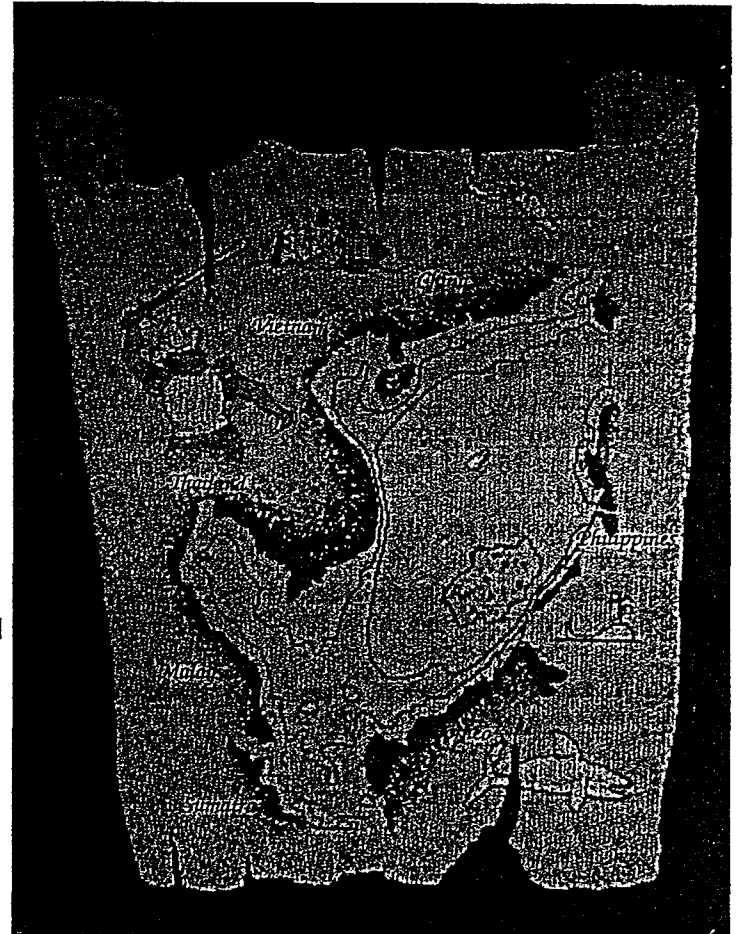

ecosystem, the SCS is rather heterogeneous, consisting of diverse ecological subsystems; and ii) the fishery statistics of the countries bordering the SCS do not relate to any ecosystem, but to national boundaries.

To address the diversity of ecosystems, we divided the SCS into 10 subsystems: A. Shallow areas (depth: 0-10 m) fringed by mangrove or other wetlands often part of estuarine systems, occurring all around the SCS, and exploited

- 50m), represented by the well-studied Lingayen Gulf, exploited mainly by trawlers.
- F. Northern coast of Borneo (depth: 10-50 m) lightly exploited by trawlers
- G. Southwestern South China Sea (10-50 m), exploited mainly by trawlers.
- H. Coral reefs (10-50 m), interspersed throughout subsystems C-F and overall representing 10% of the 10-50 m depth range in the SCS.
- I. Deep shelf (depth: 50-200 m),



Fig. 2. A representative "slice" of the South China Sea, showing its various subsystems (further defined in Table 1) and the fisheries they support.

exploited mainly by Taiwanese trawlers and also supporting various fisheries for large pelagics.

J. Open ocean (depth: 200-4,000 m), exploited only for large pelagics, and covering 46% of the total area of the SCS.

These subsystems are illustrated in Fig. 2. For five of these subsystems, we adapted existing box models, soon to be published*. For the other five

subsystems, we constructed new models based mainly on published information from the area in question. Each subsystem was then linked with adjacent subsystems by predatory links, (e.g., offshore tuna feeding on inshore small pelagics) and detritus flows, (e.g., mangrove litter being washed from inshore to deeper areas).

*Trophic models of aquatic ecosystems. ICLARM Conf. Proc. 26 (in press).

Fig. 3 shows one of the new component models constructed in this process; this represents the soft bottom community of the coast of Vietnam and southern China, including Taiwan. The model gives a representation of the average flows between the groups in the system.

The issue of fisheries statistical coverage is a serious problem noted at various international meetings; it was addressed here by using the least aggregated data that we could find, generally catch and landing statistics at the provincial level. This enabled us to separate Thai catch data into Gulf of Thailand (SCS) and Andaman Sea (non-SCS) components, and to identify which fraction of the reported Indonesian, Malaysian and Philippine catches could be assigned to that part of their coasts adjacent to the South China Sea. The biggest problem was the Chinese data - both with regard to mainland China and especially with Taiwan, whose landing statistics include catches made all over the world. To distinguish between catches taken in shallow and deeper areas, we generally split the catches based on the assumption that small-scale fisheries mainly operate at less than 10 m depth and large-scale fisheries in deeper waters.

Based on these analyses we could break down the total catch figures to more detailed groupings as shown in Table 1. Noteworthy is that these catch figures are not based directly on the

Table 1. Estimated catches ($t.km^{-2} year^{-1}$) and related statistics of ten submodels (A-J) of the South China Sea, representative of the late 1970s to mid-1980s.

Group\Model ^a	A	B	C	D	E	F	G	H	I	J	Totals or Means
1. Primary producers	-	0.988	-	-	-	-	-	-	-	-	21
2. Miscellaneous invertebrates	1.840	5.210	0.053	-	0.210	0.003	-	-	-	-	439
3. Crustaceans (excl. plankton)	1.455	0.276	0.594	-	-	0.174	0.174	0.404	-	-	411
4. Sergestids/zooplankton	-	-	-	-	0.350	-	-	-	-	-	10
5. Large zoobenthos feeders	0.026	-	0.022	0.006	-	0.012	0.086	-	0.001	-	21
6. Small demersal predators	1.075	5.409	5.449	0.408	4.514	0.136	1.541	2.375	0.036	-	1,672
7. Intermediate predators	0.140	0.440	0.251	0.867	3.220	0.060	1.556	0.129	0.077	-	664
8. Large predators	0.260	-	0.058	0.033	0.130	0.058	0.110	0.006	0.003	-	49
9. Small pelagics	0.925	0.006	1.497	-	0.340	0.283	5.126	0.831	-	-	1,047
10. Squids and cuttlefish	0.152	0.750	0.440	0.255	0.176	-	-	-	0.023	-	198
11. Medium pelagics	0.402	-	0.921	-	0.320	-	-	-	-	-	257
12. Large pelagics	0.042	-	0.050	0.050	-	-	-	0.028	0.050	0.050	157
Total catch/area	6.083	13.079	9.335	1.619	11.260	0.726	8.593	3.773	0.190	0.050	1.413
Depth (m)	0-10	0-10	10-50	10-50	10-50	10-50	10-50	10-50	50-200	200-4,000	0-4,000
Area ($10^4 km^2$)	172	21	133	280	28	144	122	77	928	1,605	3,500
Primary production ^b	3,650	4,023	3,650	3,003	913	913	2,433	2,766	730	400	1,143
Transfer efficiency ^c	0.17	0.33	0.26	0.05	1.23	0.08	0.35	0.14	0.03	0.01	0.12
Total catch ($10^4 t year^{-1}$)	1,046	275	1,242	453	315	105	962	291	176	80	4,945

^aA = mangrove/estuaries; B = reef flats/seagrass; C = Gulf of Thailand; D = Vietnam/China; E = Northwestern Philippines; F = Borneo; G = Southwestern SCS; H = Coral reef; I = Deep shelf; J = Open ocean.

^bPrimary production is expressed in wet weight in $t.km^2$ assuming a carbon to wet weight conversion of 1:10.

^cTransfer efficiency is the ratio of fisheries catch/primary production and is expressed in %.

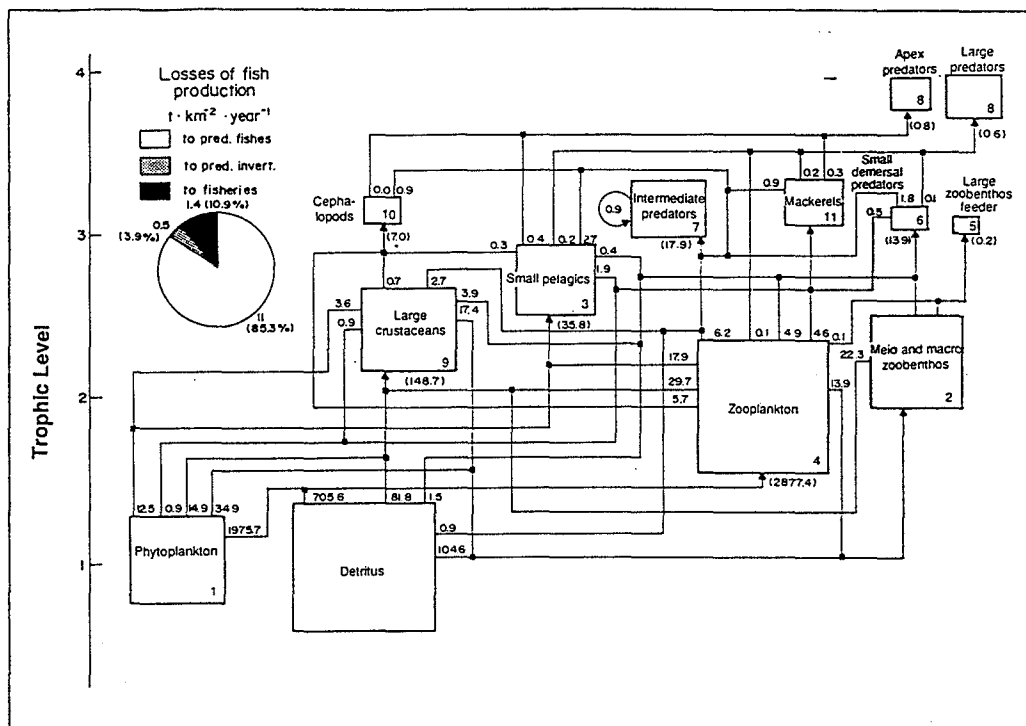

Fig. 3. ECOPATH II model of the soft bottom community (10-50 m) off the coast of Vietnam and Southern China, including Taiwan (this corresponds to model D in Table 1). The surface area of the boxes is proportional to the log of the biomasses and the numbers (if any) refer to the row numbers in Table 1. All flows are in t.km⁻².year⁻¹ (flows representing five per cent (or less) of the food intake, catches, respiration and detrital backflows are omitted for clarity).

overall catch statistics; rather they emerged from the models of the subsystems, and still they sum quite nicely to the known level of total catches. As can be seen, small demersal predators and small pelagics are the most important groups in the catches.

One result from our review of primary production data from the South China Sea is that several maps of primary productivity of the Central Western Pacific (which includes Southeast Asia and the SCS) tend to miss the strong inshore/offshore gradient of primary productivity in the region (Table 1), and hence miss the strong contribution of shallow coastal areas to overall production of biomass.

When studying the different subsystems we obtained very different transfer efficiencies from primary production to the fisheries, ranging from 0.01 to over 0.3%. These different values are not primarily due to differences in the transfer efficiencies between trophic levels (these are rather similar) but are, rather, a function of the type of fishery. Thus, low transfer efficiencies occur in systems where the fishery mainly takes

the top predators, while high transfer efficiencies occur where the catch is composed of small fish, low in the food web. This raises the question of whether the overall catches can be increased by fishing down the food web. To investigate this, we looked at fish production within each subsystem, as illustrated by the pie chart in Fig. 3. Overall, we estimated total fish production in the South China Sea at around 30 million tonnes annually, of which around 1/6 is harvested by various fisheries, the rest being eaten by fish predators. If all systems could be harvested at around the highest efficiency (0.3%), an additional 5-6 million tonnes could be taken annually from the South China Sea. This corresponds to more than a doubling of the catches.

Whether these "potential" catches can be realized or not is another question. For some areas these estimated "potentials" have already been realized. (The data used for constructing our models are generally 10-15 years old.) For others we consider it unlikely to happen, due to various constraints. However, to investigate these possibilities,

much more refined analyses are needed. Especially, modelling efforts with emphasis on dynamic descriptions of the biological interactions between fish species and of the technical interactions between fishing fleets are urgently needed. If linked with careful studies of the economic and human aspects of fishing, such analyses will provide guidelines for integrated fisheries management advice - we cannot continue to give only the traditional advice ("reduce fishing pressure"). Instead, ways must be found to accommodate the often conflicting needs of the steadily increasing number of fishers in the coastal areas and of poor urban consumers.

Further Reading

Christensen, V. and D. Pauly. 1991. A guide to the ECOPATH II program (version 2.0). ICLARM Software 6, 71 p.

Indo-Pacific Fisheries Commission. 1991. Status and trends of fisheries in the South China Sea region. Committee for the Development and Management of Fisheries in the South China Sea, Seventh Session, Hongkong, 22-26 July 1991. IPFC:DM/SCS/91/3, Bangkok, 20 p.

Pauly, D. and V. Christensen. 1991. Stratified models of large marine ecosystems: a general approach, and an application to the South China Sea. In K. Sherman, L.M. Alexander, B.D. Gold (eds.) Stress, mitigation and sustainability of large marine ecosystems. Am. Assoc. Advan. Sci., Washington, DC. (In press)

Pauly, D. and Chua Thia-Eng. 1988. The overfishing of marine resources: socioeconomic background in Southeast Asia. *Ambio* 17(3):200-206.

Pauly, D., G. Silvestre and I.R. Smith. 1989. On development, fisheries and dynamite: a brief review of tropical fisheries management. *Nat. Resour. Modelling* 3(3):307-329.

Sherman, K. and L.M. Alexander, Editors. 1989. Biomass, yields and geography of large marine ecosystems. AAA Selected Symposium III, Westview Press, Boulder, Colorado, 493 p.

*ICLARM Contribution No. 774.

V. CHRISTENSEN is Associate Scientist for the Global Comparisons of Aquatic Ecosystems Project of ICLARM's Capture Fisheries Management Program while D. PAULY is CFMP Director.